

GSGF >> REPORT

POWER GRID ELECTRICAL ENERGY STORAGE

JAN 2016



TABLE OF CONTENTS

1	The necessity for energy storage (Introduction/overview)	10
	The background of this Work Group	10
	Scope of the white paper	12
2.	Case studies	13
	Frequency Control	14
	Renewable energy integration	16
	Microgrid	18
	Load leveling/peak shifting	21
	Voltage Control	23
3.	Business Cases	25
	Currently feasible businesses	25
	Opportunities for future businesses	26
	Evolution of the market	33
4.	Conclusion	34
	APPENDICES	35
Appendix A	Members of the working group	36
Appendix B	Background of GSGF Work group activities	37
Appendix C	Work group activities	40
Appendix D	Results of the questionnaires	41
Appendix E	Some notable applications of energy storage	43

LIST OF FIGURES

Figure 1-1 The “duck curve” in California	10
Figure 1-2 Application areas of flexible demand, storage and generation	11
Figure 1-3 Two way flows of flexibility (demand side participation)	11
Figure 1-4 Energy storage system installed at a substation in Spain	12
Figure 2-1 The power grid and the applications for battery storage	21
Figure 2-2 AES Corporation’s battery frequency regulation project in Laurel Mountain	15
Figure 2-3 Batteries at Laurel Mountain installation	15
Figure 2-4 Smoothing of wind generation output at Auwahi Wind Farm	15
Figure 2-5 Toshiba’s renewable integration trials in New Mexico	17
Figure 2-6 Tokyo Gas’ renewable integration trials in New Mexico	18
Figure 2-7 Miyako Island Mega-Solar demonstration project	19
Figure 2-8 Duke Energy’s use of batteries for islanding during disasters	20
Figure 2-9 Concept of peak shifting at substation level	21
Figure 2-10 Alstom Grid’s concept for MaxSine™ storage	22
Figure 2-11 MaxSine™ site in Nice	22
Figure 2-12 Concept of voltage increase in distribution grid	23
Figure 2-13 Community energy storage in DTE Energy	24
Figure 3-1 Grid Utility Storage System in Queensland, Australia	25
Figure 3-2 Frequency control signal following capability, left: combined cycle, right: steam	27
Figure 3-3 Monthly average frequency regulation market fees in PJM	27
Figure 3-4 Battery activation depending on frequency limit strictness	28
Figure 3-5 Proposed System Services in Ireland	29
Figure 3-6 Comparison of singular use versus multiple use of batteries	32
Figure 3-7 Evolution of the market for power grid battery use	37

LIST OF TABLES

Table 2-1 Laurel Mountain project overview	14
Table 3-1 Combining applications of energy storage	31
Table 3-2 Notrees Project overview	32

LIST OF ABBREVIATIONS

This report uses the following standardized units and abbreviations.

Abbreviation	Meaning
AEP	American Electric Power
aFRR	Automatic Frequency Restoration Process
BCP	Business Continuity Plan
CAISO	California Independent System Operator
CEC	California Energy Commission
CES	Community Energy Storage
CIGRE	International Council on large Electric Systems (In French: Conseil International des Grands Réseaux Électriques)
CPUC	California Public Utilities Commission
DER	Distributed Energy Resources
DR	Demand Response
DS3 Program	Delivering a Secure, Sustainable Electricity System Programme
DSO	Distribution System Operator
DTE Energy	Detroit Edison Energy
EC	European Commission
EPB	Electric Power board of Chattanooga
ERCOT	Electric Reliability Council of Texas
EU	European Union
EV	Electric Vehicle
FCR	Frequency Containment process
FERC	Federal Energy Regulatory Commission
FIT	Feed-In-Tariff
FRR	Frequency Restoration Process
GSGF	Global Smart Grid Federation
GUSS	Grid Utility Storage System
ISO	Independent System Operator
LCR	Local Capacity Requirement
mFRR	Manual Frequency Restoration Process
NEDO	New Energy and Industrial Technology Development Organization
NERC	North American Electricity Reliability Corporation
PCS	Power Conditioning System
PV	Photo voltaic
RE	Renewable Energy
REV	Reforming the Energy Vision
RFO	Request for Offer

RFP	Request for Proposal
RR	Reserve Replacement Process
RTO	Regional Transmission Operator
SCE	Southern California Edison
SOW	Statement of Work
SWER	Single-Wire Earth Return
TSO	Transmission System Operator
WG	Work Group
XP	Xtreme Power

SUMMARY

GSGF annually sets up multiple work groups (WG) for important smart grid related topics. In 2015, three WGs were established: the Power Grid Electrical Energy Storage WG, the Flexibility WG, and the Cyber Security WG. The Power Grid Electrical Storage WG consists of members from utilities, electrical equipment manufacturers, and research institutes from several countries around the world. Multiple questionnaires and meetings were conducted, in which the members shared insights on challenges and opportunities in their respective countries. This report is based on the results of those activities.

The increase of electricity generated from distributed renewable energy sources in the electrical grid has made it difficult to maintain the balance between electricity supply and demand, making grid operation more complex. In future grid operation, flexibility in various forms (not only from traditional supply side flexibility) will become necessary to support stable grid operation. This white paper focuses on electrical energy storage, and especially on batteries, which are recognized as one promising source of flexibility, with advantages such as fast response time, scalability, low geographical constraint, and short project lead time.

Many stakeholders still consider batteries as too expensive for use in grid operation support. However, the results of the case studies shown in this report show that in some cases batteries are already economically viable. In PJM in the US, for example, batteries are used commercially in the frequency regulation market, and in Queensland, Australia, batteries are used as the least expensive option for upgrading local grids.

It should be observed that for most power grid application uses, there are still economical hurdles to overcome. If the regulatory framework is altered to evaluate performance by a technologically neutral standard, battery energy storage will have many advantages over other technologies, because of its strengths. This white paper suggests that markets will evolve from batteries first being used for frequency control, followed by local peak shifting. This would lead to an increase in battery production and a decrease in cost, creating opportunities to use batteries for other applications, such as microgrids and renewable integration use. To speed up market development, using batteries for multiple applications would be effective, but regulatory support is needed to realize the possibility to earn multiple revenue streams.

1 THE NECESSITY FOR ENERGY STORAGE (INTRODUCTION/OVERVIEW)

The background of this Work Group

The status and changes relating to the power grid

The power grid of today's world is changing, and is drifting away from the model that prevailed in the 20th century. The main drivers for change are that increased amounts of intermittent renewable energy are being put into the grid, and decentralized generation is becoming common. These changes particularly pose problems for the distribution grid, which originally was not designed for large quantities of distributed generation.

The rate of introduction of photo voltaic (PV) and wind turbine generated electricity is high in many areas, and fundamental changes in the dynamic of demand and supply on a large scale are imminent. The introduction of PVs lead to local generation becoming abundant during the day, which reduces the need for central generation during the same time period, while the introduction of wind energy adds generation that is difficult to predict.

As a representative example, the so-called “duck curve” in California shows what ultimately will happen when PVs are introduced in large amounts. The daytime net load (subtracting the electricity created by the PVs) will become lower, while the evening peak when people come home from work stays the same. This will create the need for fast ramping in the late afternoon.

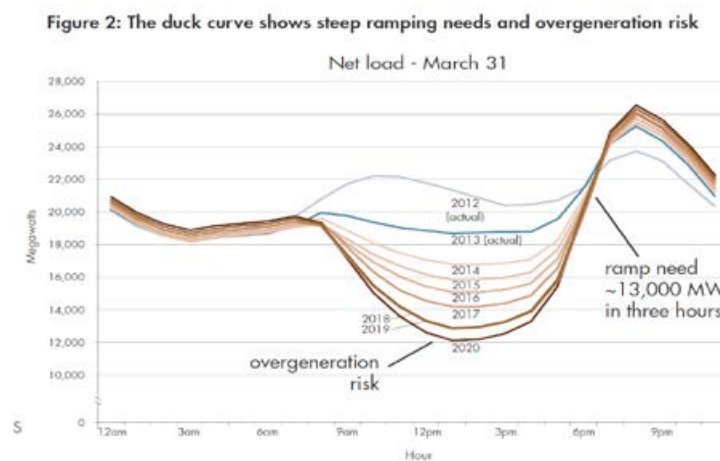

Figure 1-1 The “duck curve” in California

Source: <https://www.caiso.com/Documents/DR-EERoadmap.pdf>

Thus, we see a need emerging for new technical and commercial use cases that can balance the demand and supply, i.e. that can add flexibility to the power grid.

The expectations for flexibility

The need for flexibility is defined in the Smart Grid Coordination Group document for the M/490 Mandate¹: “Smart Grids Methodology & New Applications - SG-CG/M490/L” as follows:

- In this new era, keeping the balance between demand and supply, as well as using transmission and distribution capacity as economically as possible without overloading and blackouts are major challenges. This transition calls for a paradigm shift. Not only may a two way flow of power be introduced because of decentralized generation, but also a two way flow of flexibility is required.
- Flexibility can be sourced from a range of generators, storage and demand. Both on supply as on demand side, flexibility can be provided. On the demand side, flexibility is provided by industrial, business and residential customers, directly or via a flexibility operator/ aggregation service provider (for residential customers).

¹M/490 is a mandate which supports European smart grid deployment, and is a result of discussions between CEN, CENELEC and ETSI.

- The application areas where flexibility in supply and demand provides value can roughly be divided into two main clusters of use cases: use of flexible demand, storage and generation in commercial and technical use cases.

In this white paper, the focus will lie on System Operation and Grid Operation application categories, as defined below. These applications are particularly important in tackling the grid issues that arise from introducing renewable energy. Electrical energy storage is one set of technologies that is deemed to be effective for this.

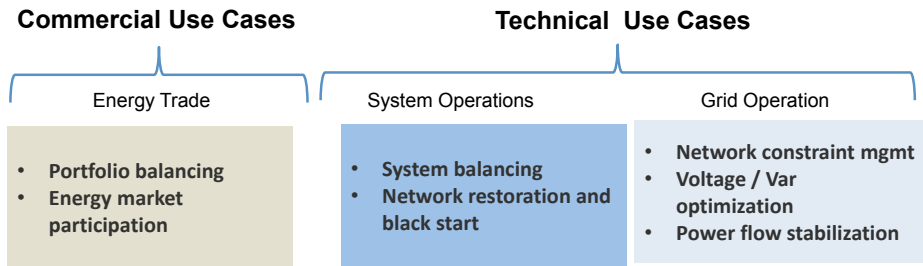

Figure 1-2 Application areas of flexible demand, storage and generation
Source: SG-CG/M490/L_ Flexibility Management

Why we need electrical energy storage

As mentioned in the EU’s M/490 Mandate, a paradigm shift is necessary to actively encourage “demand side participation”, to support the grid in the face of large scale introductions of renewable generation.

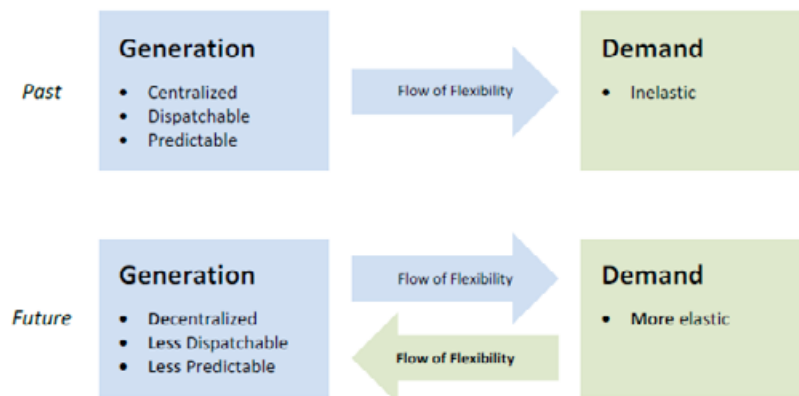

Figure 1-3 Two way flows of flexibility (demand side participation)
Source: SG-CG/M490/L_ Flexibility Management

In activating such demand side participation, several criteria are important:

- Fast response (being able to respond to rapid changes in generation/load)
- Scalability (being able to distribute according to need regardless of size, without losing functionality)
- No geographical constraint
- Short lead time (fast implementation)

Fast response is key because of the necessity to ramp up and down quickly to cope with fluctuations from intermittent generation, such as solar and wind power, but also with conventional generators that fail.

Regarding the scalability and lack of geographical constraint, this can improve the use rates of existing infrastructure, and can ameliorate congestion in the transmission and distribution network by shifting the peak at the local level. Furthermore, being able to introduce a new asset with a short lead time is important when solving local flexibility problems.

Batteries fit these conditions perfectly. Therefore, this white paper will look at battery energy storage specifically. It is important to note that batteries for energy storage in the grid does not represent a silver bullet that immediately solves all future grid problems, nor is it the only option for improving grid operation conditions; batteries compete with other storage technologies, conventional generators, demand response, wide area network operation, etc. Rather, batteries should be considered as one important cog in the wheel to preserve grid stability over the long run, when more variable and distributed generation will unavoidably be connected to the grid.

Scope of the white paper

This white paper will focus on the possibilities of battery energy storage in the distribution and transmission network (i.e. grid-scale storage and substation-scale storage). Behind-the-meter storage and storage at conventional generation sites will be excluded.



*Figure 1-4 Energy storage system installed at a substation in Spain
Source: http://www.nedo.go.jp/news/press/AA5_100459.html*

This white paper is not an overview of existing literature on the subject (even though some will be used accordingly); it is the outcome of the discussions and questionnaires undertaken by the work group. The purpose is to give insights into how stakeholders view the situation. From there, the possible applications for storage will be discussed.

The structure of the white paper is as follows: The second chapter defines the various services that batteries can perform effectively in the grid; the third chapter looks at already economically viable use cases and future feasible businesses; the fourth chapter concludes the white paper. A summary of the questionnaires can be found in the appendices.

2 CASE STUDIES

Battery storage is effective for improving grid operation, but for batteries to become an essential part of the power grid, it must first become an economically viable choice for service providers. This is not yet the case for many of the possible applications, and for most markets in the world. However, there are multiple demonstration projects under way in many parts of the world, and some applications have been introduced on a commercial operation basis.

In this chapter, several case studies from various countries were collected via workshops, telephone conferences, and participation in international events.

It is important to note that in the actual use, batteries tend to perform several tasks at once, hence it is difficult to strictly classify application as one single purpose; below, the projects are classified according to their most prominent feature.

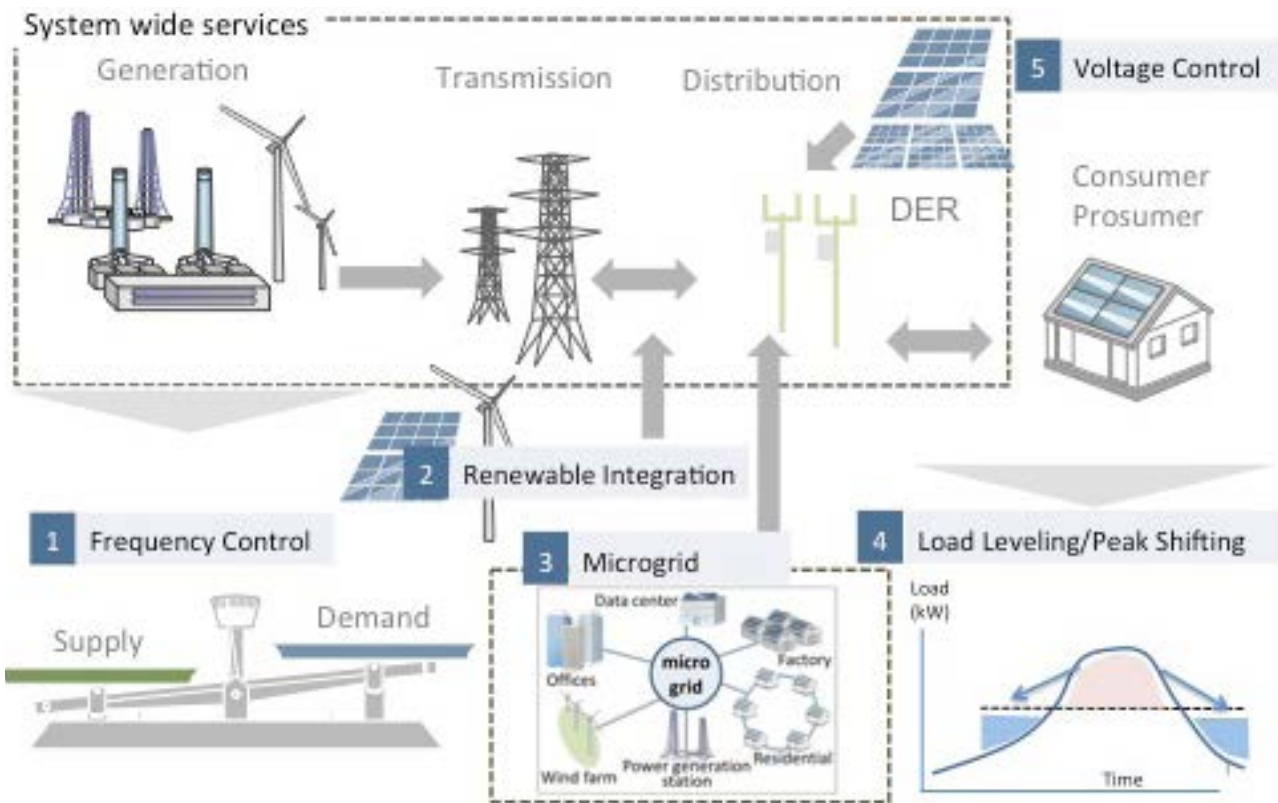

Figure 2-1 The power grid and the applications for battery storage

In the section below, each application is explained together with examples of actual implementation for grid operation.

Frequency Control

"System frequency is a continuously changing variable that is determined and controlled by the second-by-second (real time) balance between system demand and total generation. If demand is greater than generation, the frequency falls while if generation is greater than demand, the frequency rises."²

To keep the system frequency in balance, controlling generation on the supply side, using demand side participation, or both, are needed.

In this report, the word "frequency control" includes both long-term and short-term measures. These controls are divided into the following³:

- **Primary control:** local automatic control which delivers reserve power in opposition to any frequency change;
- **Secondary control:** centralised automatic control which delivers reserve power in order to bring back the frequency and the interchange programs to their target values;
- **Tertiary control:** manual change in the dispatching and unit commitment in order to restore the secondary control reserve, to manage eventual congestions, and to bring back the frequency and the interchange programs to their target if the secondary control reserve is not sufficient.

The names of these three controls differ depending on country and area. For example, the word "control" is equivalent to "reserve", "response", or "control reserve". "Secondary control" is partially equivalent to "spinning reserve" in the US. In Europe, primary control is referred to as "Frequency Containment Process" (FCR), secondary control as "Frequency Restoration Process" (FRR, which includes both manual (mFRR) and automatic (aFRR) controls), and tertiary as Reserve Replacement Process (RR).

Technologically, batteries are suitable for short-term frequency control such as primary control and secondary control, due to their capability of changing output level, and switching from discharge to charge mode, quickly.

Frequency regulation – The United States

In many RTO (Regional Transmission Operator) and ISO (Independent System Operator) markets in the United States, until now, generation units have been paid according to the amount of capacity they provide (the amount of extra generation they can provide at any given time), without regard to the actual performance of the generator when it is providing frequency regulation service. This has effectively penalized batteries (and other units able to provide precise regulation, for example flywheels), since they are extremely quick to follow regulation control signals, but generally have a higher cost per unit of generation provided.

Historically, regular generation units have provided frequency regulation services. AES Corporation, however, has decided to break this pattern, and has moved into several U.S. markets providing frequency regulation with large battery installations. One such unit is the AES Laurel Mountain Plant, which provides frequency regulation for PJM Interconnection, a regional transmission organization (RTO) for the eastern US, where AES is using a battery provided by NEC Corporation.

Table 2-1 Laurel Mountain project overview

Developer	AES Corporation
Battery	Li-ion battery 8MWh/32MW (provided by NEC Corporation)
Schedule	Commissioned in 2011.
Markets	Primary commercial market – PJM (PJM frequency regulation)

²<http://www2.nationalgrid.com/uk/services/balancing-services/frequency-response/>

³A Survey of Definitions and Specifications of Reserve Services, Manchester University, 2005

<http://www.ee.washington.edu/research/real/Library/Reports/Survey_of_Reserve_Services.pdf>

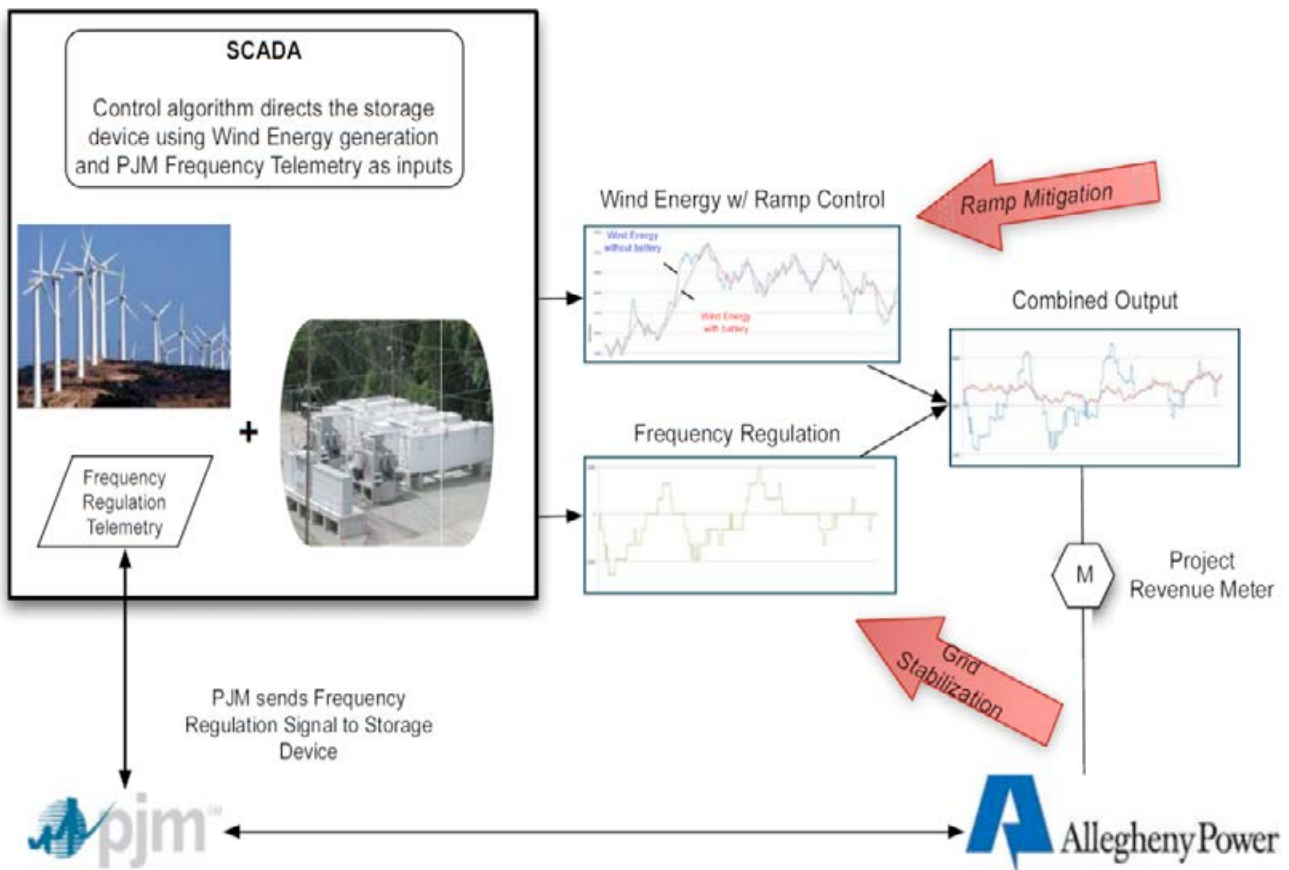

Figure 2-2 AES Corporation's battery frequency regulation project in Laurel Mountain
 Source: "AES Laurel Mountain Overview", AES Corporation

The battery is situated at the Allegheny Substation (138kV), which is next to the 98MW Laurel Mountain Wind Project, and consists of 16 battery containers and 8 inverter containers to host the 32MW/8MWh facility. Here, the battery provides services to smooth the output of the wind farm (load leveling), as well as providing regulation services to the PJM area. The project has been in operation since 2011, and received the 2012 Excellence in Renewable Energy Award for Wind Project of the Year. This project has demonstrated the possibilities of using batteries as grid storage, showing an availability of 99%, and following the fast response "RegD" signal⁴. Increasing the frequency of charging and discharging batteries is often considered to be the cause of shortening battery lifetime, but in the case of frequency regulation, deep discharging (discharging to below 10% state of charge) is rarely the case, so the lifetime of the batteries is not affected.



Figure 2-3 Batteries at Laurel Mountain installation
 Source: NEC Corporation

⁴A signal that indicates level of remuneration for the providers of frequency regulation in the PJM market. It was implemented as a means to follow FERC Order 755, which is mentioned later in this paper. The introduction of this signal has led to higher price awards for frequency regulation services, but a lower total cost for PJM.

Frequency regulation – Germany

Similar applications are emerging in Europe. Younicos AG has built the first European commercial battery park in Schwerin, Germany, where a 5MW/5MWh battery is located next to a 110kV substation (Schwerin-Lankow). The battery park is built for the German DSO (Distribution System Operator) WEMAG AG, next to a wind-power intense area.

The battery will primarily participate as a commercial actor on the German frequency regulation market (“Primary Power Market”), but can also provide black start and other services.

Renewable energy integration

Since variable generation sites such as PV and wind turbine facilities produce electricity only when the sun shines and the wind blows, grid operators cannot control when they generate power. Weather phenomena and need for electricity do not necessarily coincide, therefore this can result in an imbalance in the grid, and the grid operator must manage other resources in order to ensure stability.

Some grid operators have introduced minimum “ramp rates” (how fast a generator can change its output) for solar and wind parks. Some grid codes even include requirements on response capabilities for frequency regulation, which are costly for wind and solar generation units. For example, in countries with large amounts of wind generation, such as Germany and Spain, there have been instances of curtailing wind generation to prevent the grid from being overloaded (in many cases, the surplus can be sent to other countries, if the interconnectors have enough capacity).

In order to integrate these energy sources into the electricity grid more effectively, batteries and other energy storage systems can be placed near the generation site, improving the predictability of the generation, and providing the ability to shift the generation by several hours. Already, some such cases are in operation. One advantage with batteries is that they are easily moved: solutions where the battery is sold together with a power conditioner in a large container, ready to be placed anywhere, are already available. This way, batteries can be used as a temporary solution for grid operators to stabilize output from a variable generation site until a more permanent solution is found.

Furthermore, having a battery installed together with a wind or solar park increases the predictability of output, hence reducing uncertainty in the project revenue stream. This can improve the conditions for investment and project finance.

This concept can be observed from the results of NEC’s wind integration project at the Auwahi Wind Farm on Hawaii. Here, NEC has installed a 11MW/4.4MWh lithium-ion battery next to the wind farm to smooth the up- and down-ramping of the wind farm. The black line shows the electricity put into the grid, compared to the actual output of the wind farm, which is shown in purple.

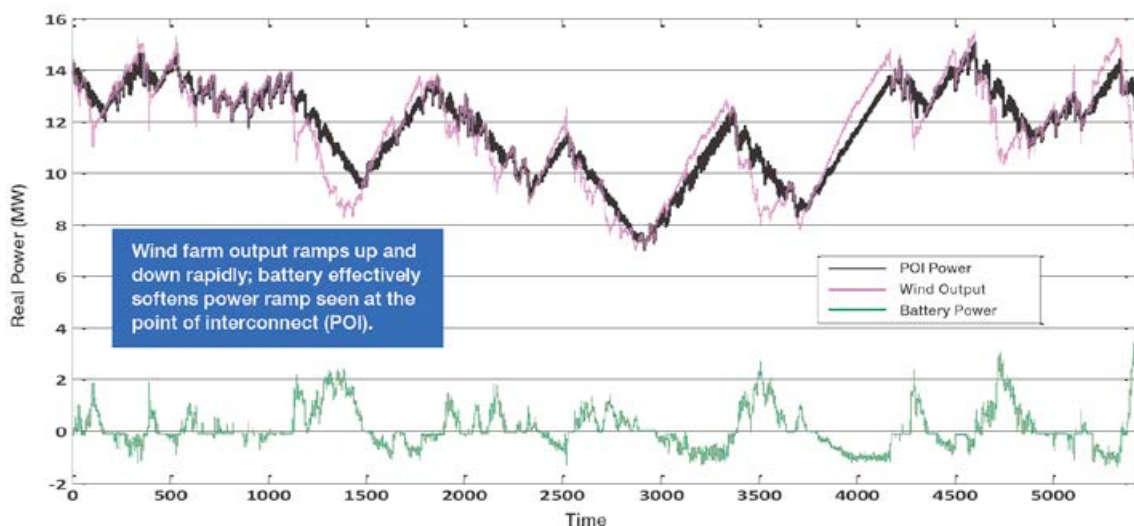

Figure 2-4 Smoothing of wind generation output at Auwahi Wind Farm
Source: NEC Corporation

PV Integration – Italy

In Italy, many solar panels have been installed in the distribution grid, resulting in the grid becoming so fragile that energy storage is needed to ensure stability and avoid blackouts. A 2MW/2MWh li-ion battery has been installed in Enel Distribuzione's distribution grid, connected to the Chiaravalle primary substation in the region of Calabria. In this area, solar and wind generation has been widely installed, and the battery is expected to ameliorate the intermittency of the renewable generation.

The battery will be subject to a series of trials, where the possibility of the following capabilities will be tested: peak shaving, power balancing, power quality, voltage regulation and frequency regulation.

Apart from this trial, Enel has been introducing batteries for integrating renewable energy at a high pace, with batteries in Catania (1MW/2MWh), Isernia (750kW/500kWh), Potenza Pietragalla (2MW/2MWh), Puglia and Sicilia (similar batteries to the one used in Calabria). The basic location for these batteries is next to a substation, to help with both renewable generation integration, and relieving the substation of capacity strains.

Tests for determining least battery capacity needed – The United States

When it comes to integrating renewable energy into the power grid, there are many questions concerning the necessary capacity of the energy storage. For example, how much storage capacity would be needed to introduce 5MW of wind energy into a local grid?

In NEDO's (New Energy and Industrial Technology Development Organization) demonstration project in New Mexico, U.S., batteries were used that run partly on solar power. The batteries were utilized at two separate microgrid test sites, one each in both Los Alamos and Albuquerque. The project seeks to determine the necessary storage capability in a grid where solar represents 20-50% of the total generation capacity.

In the Los Alamos demonstration, a 1MW/6MWh NaS battery and a 0.8MW/2.3MWh lead acid battery were introduced in a grid where 1MW solar had been installed. Trials are ongoing in order to find the minimal amount of storage capacity necessary for stable grid operation. Trials also include combining the battery with demand response (DR), to see how much DR can further decrease the needed amount of storage.

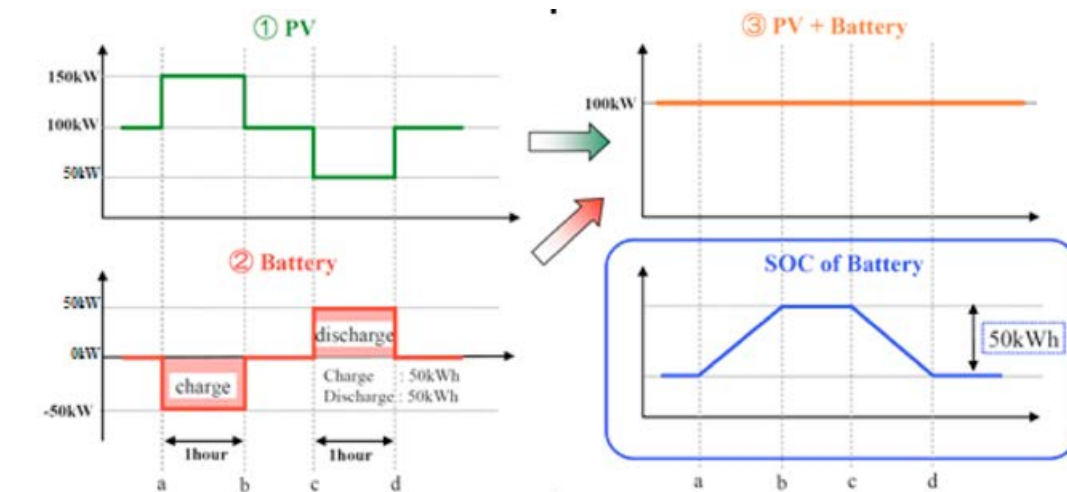

Figure 2.5 Toshiba's renewable integration trials in New Mexico

In the figure above, only a battery is used with the PV system, without a gas engine. In this system configuration, a 50kWh battery would be necessary for system stability. However, by adding a gas engine, as is shown in the figure below, to help optimize the work of the battery, the necessary size of the battery can be reduced to 8.3kWh. In actual testing, Tokyo Gas has managed to reduce the size by 17.7%. In the Albuquerque demonstration project, a similar concept is tested, but instead of relying on a battery and DR, a gas engine was introduced to supplement the battery and help reduce the needed amount of battery storage in a small grid. The basic scheme of this project is shown in the figure below.

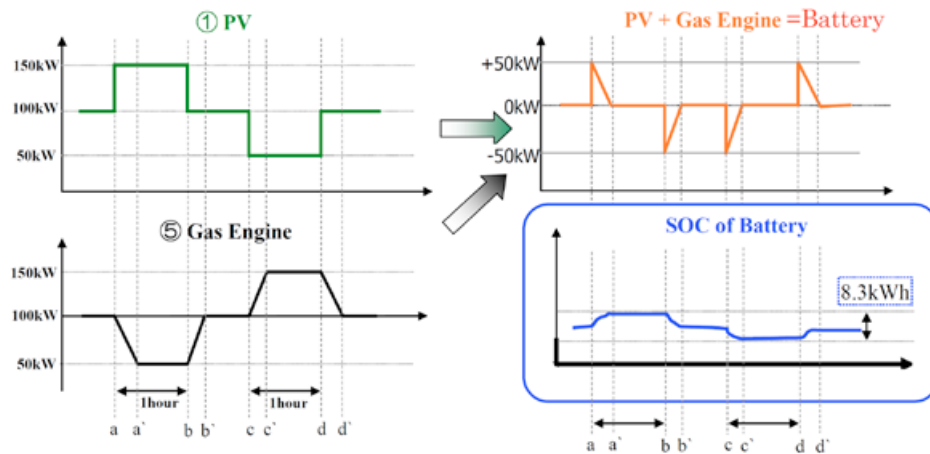

Figure 2.6 Tokyo Gas' renewable integration trials in New Mexico

Since combining battery systems with variable generation to create stable systems is still expensive compared to conventional solutions, attempts to minimize the required size of the battery are very important, and here it is shown that the use of DR and small-sized gas engines can supplement batteries adequately.

Microgrid

At the CIGRÉ C6.22 Working Group, the “Microgrid Evolution Roadmap⁵” was produced, in which microgrid is defined as:

- Microgrids are electricity distribution systems containing loads and distributed energy resources, (such as distributed generators, storage devices, or controllable loads) that can be operated in a controlled, coordinated way either while connected to the main power network or while islanded.⁶

Microgrids, while interconnected to the main power network, can minimize the effect of variable generation on the larger grid, while using local renewable generation to the extent possible. This can help with minimizing investment in the transmission grid. This is especially effective in isolated island grids: there are many smaller isolated islands, which basically rely on expensive diesel for power generation. Batteries could help increase the efficiency of the grid, as well as increase the share of renewables, and reduce the risk of blackouts due to diesel engine failures. Due to the nature of such grids, they are susceptible to sudden changes in supply or demand, and from that perspective batteries are valuable.

On the other hand, microgrids can be used for “intentional islanding”. This is helpful during special events, such as a disaster, to provide important consumers with uninterrupted power supply, using generators and energy storage systems that are placed nearby to create a temporary microgrid.

In many disaster-ridden parts of the world, such as Japan, southern and western US, and Southeast Asia, the use of batteries is seen as an opportunity to ensure secure supply in local areas even if an earthquake strikes or a major storm hits. Microgrids are the target of attention as they can potentially be a huge market for batteries.

Compensation for variable generation on isolated islands – Japan

Okinawa Electric Power Company has started microgrid projects on four isolated islands south of the Japanese main islands, in Okinawa prefecture. One of those is Miyako Island, where a utility-sized solar PV installation (4MW) has been constructed, and a total of 4.2MW of wind generation is connected to the island grid. The peak demand of the island is 50MW, and it has 76.5MW of diesel and gas generation capacity.

On the island, a 4MW/28.8MWh NaS battery and a 100kW/200kWh lithium-ion battery have been installed to help level the output of the solar PV plant, as well as to optimize grid operation. This project was supported by the Japanese Ministry of Economy, Trade and Industry. The results from the project are as follows:

⁵A technical brochure that aims to identify the main elements that need to be implemented to construct working microgrids.

⁶<https://building-microgrid.lbl.gov/microgrid-definitions>

- The batteries helped level the variable generation of the solar power plant. Therefore, the output of the solar power plant can be properly predicted, and becomes a dispatchable resource.
- The batteries contributed to the frequency regulation of the island, lowering the need for gas engines to provide regulation power.

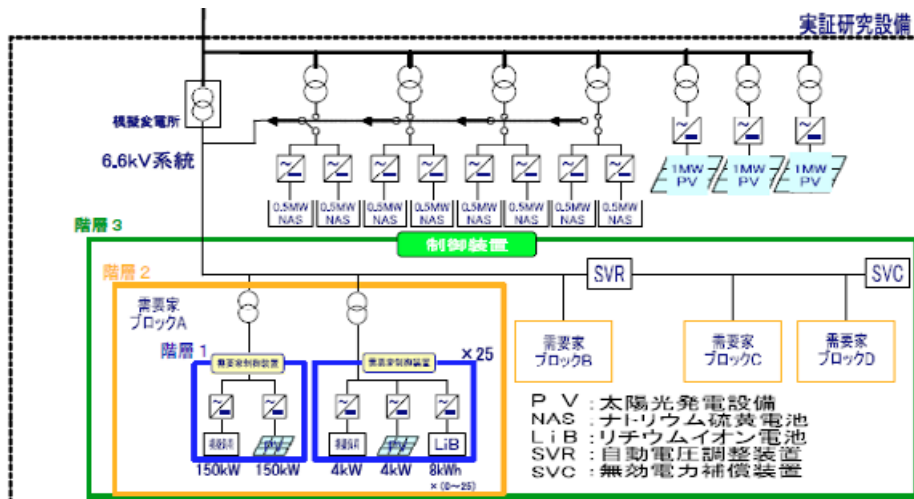

Figure 2-7 Miyako Island Mega-Solar demonstration project
Source: Okinawa Electric Power Company press release (2010/10/15)

Securing important generation in case of network disruption in Duke Energy – The United States

As mentioned above, microgrids are in larger grids as well. Duke Energy, operating in the southeastern US, has introduced a 50kW site (McAlpine Creek demonstration project) combined with a 500kW battery at a public facility (a fire station) which requires uninterrupted power supply, in case of emergencies. These will be used for intentional islanding in the case of an emergency, or when other parts of the distribution network cannot support stable operation, due to trees falling over the distribution lines during a hurricane, for example. The demonstration project is ongoing.

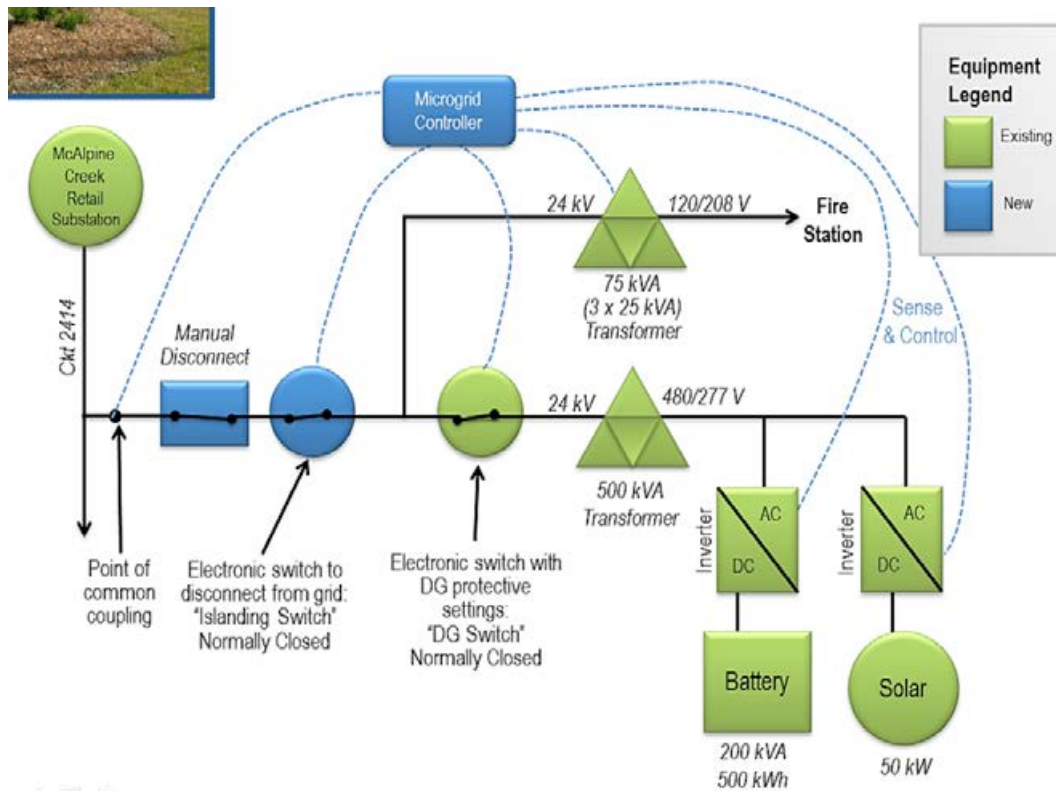

Figure 2-8 Duke Energy's use of batteries for islanding during disasters
Source: "McAlpine Creek Demonstration", Duke Energy

Intentional islanding capabilities at EPB – The United States

EPB (Electric Power Board of Chattanooga) has, with the help of the US Department of Energy Smart Grid Investment Grant, introduced a distribution automation system with self-healing capability in all parts of its 12kV distribution network. EPB has introduced 1,194 of the so-called "Intellirupters", automatic fault interrupters and reclosers, produced by S&C Electric Company. Whereas many distribution companies in the US have started automating their grids, EPB is the first to make their grid fully automatic, with high self-healing capability.

Having installed these automatic circuit fault interrupters and reclosers, the distribution grid can automatically test and determine whether a fault is temporary or permanent; if the fault is temporary, the devices restore power within seconds with fault currents, without damaging the equipment (Automatic Restoration).

In the next step, EPB is considering installing distributed renewable energy together with energy storage batteries. These will be located between two Intellirupters where there are important customers connected, in order to be able to operate in intentional islanding mode in case of grid failure.

Even though EPB has not introduced batteries, this example shows that interest for intentional islanding is growing in the US, for larger grids as well – and subsequently the market potential for batteries – as the needs for islanding are growing as disaster prevention.

Load leveling/peak shifting

The next application is load leveling/peak shifting at the local (distribution) level. As electricity demand grows, upgrading of substations and distribution lines are necessary to handle the higher peak loads. However, with grid upgrades, the grid utilization rate, i.e. how much of the capacity is used over time, goes down in the short term, making the payback period for grid investments long.

Furthermore, as distributed generation is introduced at the customer level, the grid utilization rate tends to go down. This is because the grid needs to be able to handle the highest levels of demand. When many customers have PVs installed, for example, they will not use the grid as much as before, even if they sometimes, such as on a rainy day, rely solely on electricity from the grid during peak demand.

Battery energy storage devices can be placed at the distribution substation in order to postpone, or defer, an upgrade of said substation. This will increase the profitability of the grid. In some areas, batteries are already being introduced as an economically viable alternative to conventional upgrades.

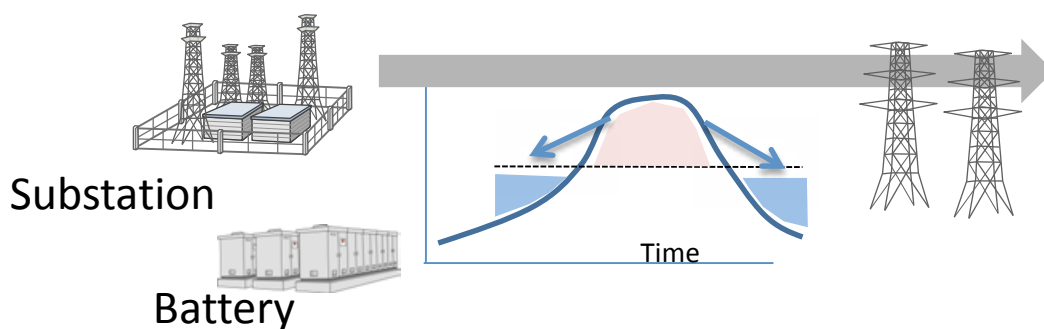

Figure 2-9 Concept of peak shifting at substation level

Peak shifting at substation level – The United States

In 2013 California mandated that 1.325GW of energy storage be installed by 2020. In the first LCR procurement round performed by SCE, AES Corporation was awarded the installation of a 100MW/400MWh li-ion battery⁷, which was announced in November 2014, to be installed in Alamitos. AES' 100MW battery will replace an old peaking gas plant, placed at a substation in Alamitos, California, to provide for peak power at the substation level. This shows that there are already instances where battery energy storage can economically compete with traditional peaking power plants.

Another utility in California, Pacific Gas & Electric (PG&E), is also targeting substations as a potential market for energy storage. As their RFO (Request for Offer) process will finish in December 2015 the outcome is not clear yet, but in their RFO they have requested information "that would enable PG&E to defer otherwise necessary investments at up to five distribution substations". In other words, peak shifting at substations would help avoid premature upgrades of distribution equipment.

AEP (American Electric Power) has endorsed the same vision by piloting this use of battery energy storage use in 2006, with the installation of a 1MW/7.2MWh NaS battery in western Washington. AEP sees their network having batteries placed at many substations to avoid upgrading the distribution network to meet peak electricity demand.

Peak shifting at substation level in Nice – France

Alstom Grid has developed a battery application called MaxSine™ eStorage for peak shifting at the local substation level that can house up to 2.5MW of battery power. The battery is manufactured by SAFT. This application will work to minimize the congestion in the local grid, and manage and optimize the use of solar power by creating a virtual microgrid. As a result, maximum integration of variable renewable generation is possible. The concept of the application is shown below.

⁷SCE was required to procure 50 MW of energy storage in the first LCR procurement round, but ended up procuring 260 MW. This shows the cost-competitiveness of energy storage solutions in California.

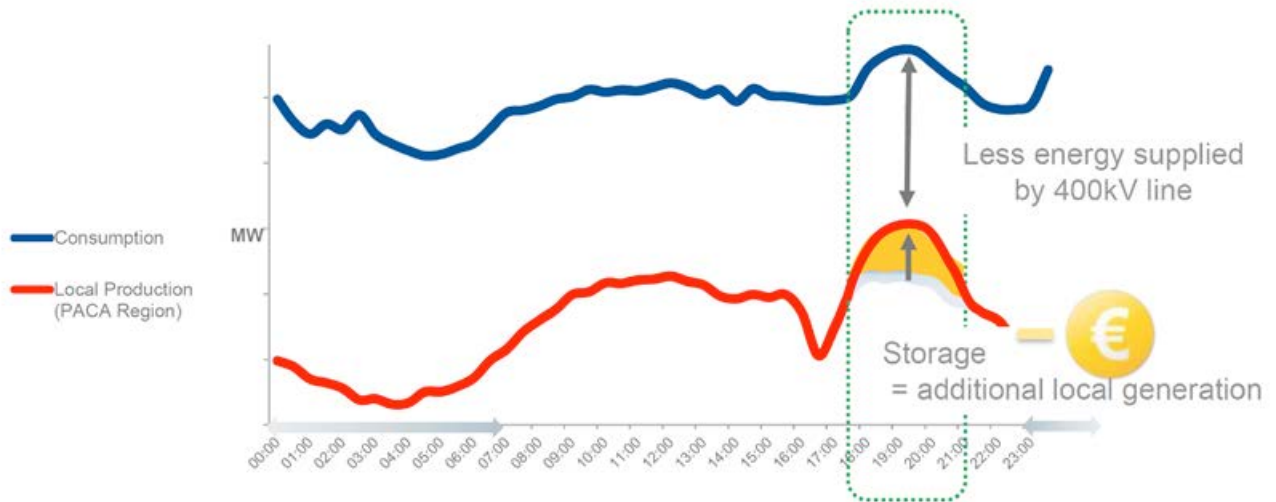

Figure 2-10 Alstom Grid's concept for MaxSine™ storage
 Source: Alstom Grid GSGF presentation material

At Nice Grid, the MaxSine™ eStorage has been installed at 4 substations in the electrical grid of Carros. Below is the outline for one of them.



- 1 MW / 560 kWh in operation since Feb 2014
- Connected to the MV distribution grid at the primary substation (between DSO & TSO connection)
- Battery: SAFT
- Converter , Grid connection and control system : ALSTOM GRID

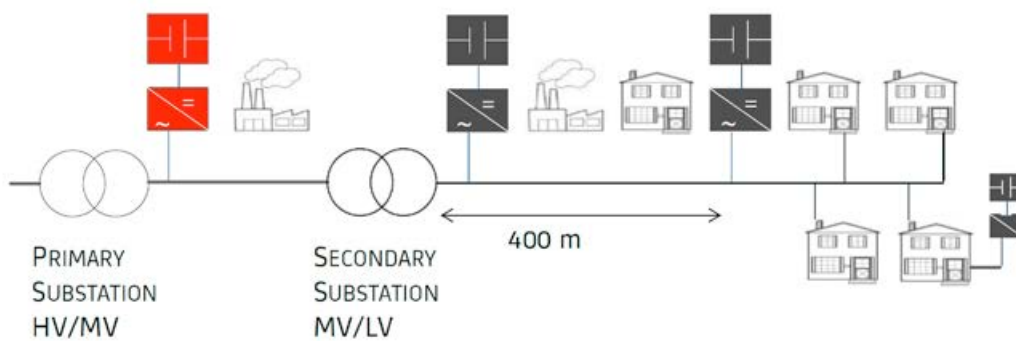

Figure 2-11 MaxSine™ site in Nice
 Source: Alstom Grid GSGF presentation material

Voltage Control

The final application defined in this white paper is voltage control performed by batteries in the distribution grid. As the introduction of distributed energy resources accelerate, problems with voltage fluctuations occur. The voltage level in the grid must be kept fairly stable (for example, it is 101 +/- 6V in Japan in the final part of the distribution grid). However, when many PV installations are generating in the same area at the same time, the voltage levels can increase to dangerous levels, as seen in the figure below.

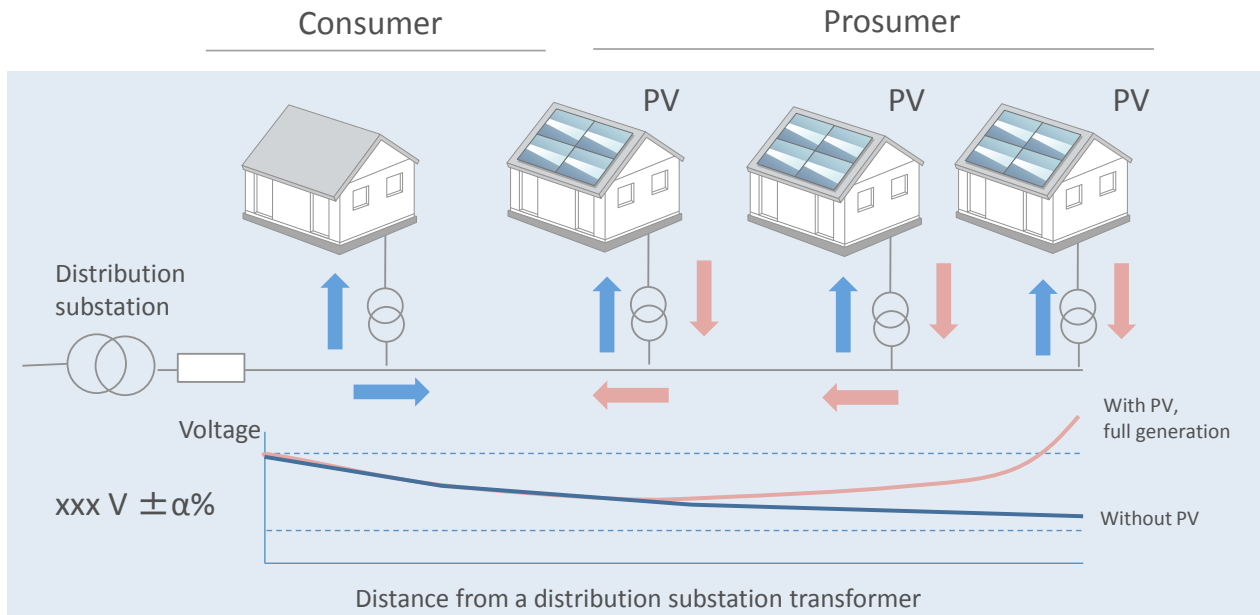

Figure 2-12 Concept of voltage increase in distribution grid

Currently, the industry is looking at various ways of solving this issue. It is possible to solve this problem by restricting the generation output from the distributed generation sources, but this can be considered a waste of renewable electricity. Another possible solution is using batteries installed near the power source to absorb electricity in order to lower the voltage levels.

Community Energy Storage in Detroit – The United States

In the United States, there are demonstrations being made under the name of “Community Energy Storage” to solve the kind of issues that renewable energy integration presents, one of them being voltage control.

In Detroit, DTE Energy (Detroit Edison Energy) has demonstrated 25kW/50kWh local distribution battery systems as part of Community Energy Storage. These energy storage units will be placed next to transformers on poles, supporting a few consumers who have solar panels installed on their rooftops, or a small commercial load.

The main use of the batteries is supporting voltage control, but local peak shifting and backup power are also offered as services. For this project, DTE Energy also offers the possibility of recycling used electric vehicle batteries for use as energy storage in the grid. Control algorithms that can optimize battery life are also employed.

Below is an image showing the outline of the demonstration project, which also includes a 500kW li-ion battery combined with 500kW utility scale PV installation.

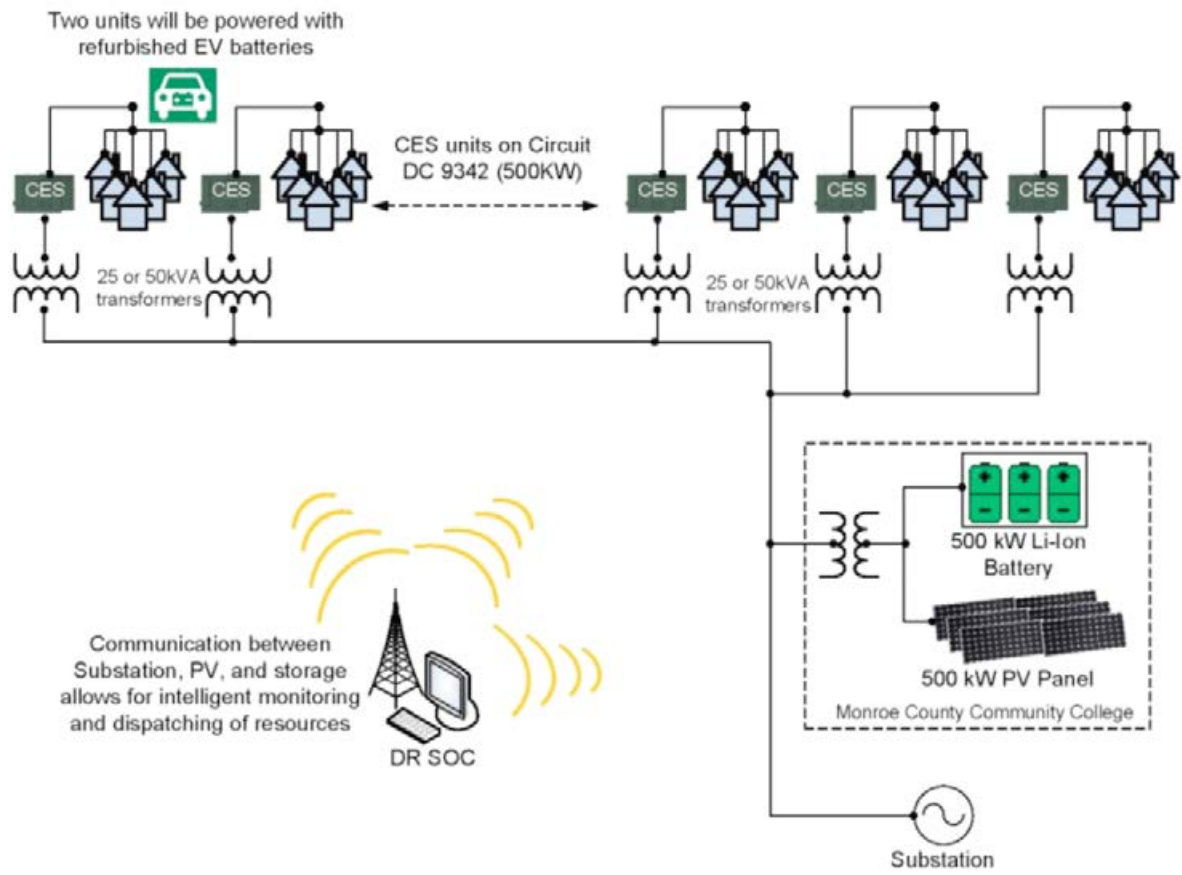

Figure 2-13 Community energy storage in DTE Energy
 Source: "Community Energy Storage for Grid Support", Detroit Edison (US DoE Energy Storage Program), 2012

3 BUSINESS CASES

Chapter 2 looked at a few possible applications for battery energy storage in solving grid stability issues, especially those arising due to the increased introduction of renewable variable generation. However, in Chapter 2 the focus was primarily on the application and introduction of cases where demonstration projects and commercial projects have begun. In Chapter 3, the focus will be on the economics of power grid battery storage. In some areas of the world, some of the applications that were described in Chapter 2 are already economically feasible.

Also, with the power business being reliant on regulations for stable operation, the state of regulation is important for the economics of batteries as grid storage. In this chapter, cases where regulation change have laid the groundwork for economical operation are discussed, further noting policy changes that might open up future markets, and guiding the way for other markets to tread the same paths.

Currently feasible businesses

First, it is important to note that in some cases the use of batteries makes more financial sense than upgrading the electric grid or installing new generation.

Peak cut for SWER line in Queensland – Australia

Ergon Energy, which operates in Queensland, Australia, has started introducing batteries in their SWER (Single-Wire Earth Return) lines. SWER lines are used in areas with sparse population. Due to the population density being low, and the area the electrical grid covers in Queensland being large (larger than Texas), the grid is highly radial.

Lately, the utilization rate of the grid has been dropping significantly due to high solar PV penetration. On the other hand, the peak demand remains the same, and at the same time, the regulations are changing to lower the burden on the consumers, putting more and more pressure on Ergon Energy, as the revenue from grid use and electricity retailing is dropping.

Since the price of batteries have simultaneously been going down, Ergon Energy decided to deploy batteries on constrained SWER lines, in order to cut the local peak and postpone further investment for strengthening of the distribution network. The solution, called Grid Utility Storage System, or GUSS, that Ergon Energy uses, consists of 25kW/100kWh li-ion batteries. Using this technology, Ergon Energy has managed to avoid unnecessary costs while improving their service to the consumers.



Figure 3-1 Grid Utility Storage System in Queensland, Australia
Source: Ergon Energy

Frequency regulation in PJM – The United States

After the introduction of Pay for Performance (based on FERC Order 755, see the next part for details) in PJM, a new metric for determining the price for frequency regulation has been added. This metric takes into account how accurate the frequency regulation providing resource can follow the regulation signal sent out by the system. Due to li-ion batteries being very quick to accurately change output level, this rule change effectively rewards the use of batteries.

The example described in Chapter 2 under Frequency Regulation, where AES Corporation deployed a battery for frequency regulation at Laurel Mountain in the PJM area, is one of many examples of batteries entering PJM's market. According to Energy Storage Update, there are 23 active storage projects in PJM's fast ramping storage capacity, of which most are li-ion battery units of 20-32MW⁸.

Opportunities for future businesses

The economics of batteries used for grid storage consists of two parts: the economics of investing in battery storage, and the return, compared to other alternatives. The economics of battery storage can be improved either by decreasing the initial cost and lifetime cost of the battery, i.e. lowering the investment hurdle, or by introducing new value propositions that can improve the return rate of the battery storage. This can be done either by proposing new services, or by changing the market and regulations so that the value of the battery's services are adequately remunerated.

In the current situation of the market, many projects are funded partly by subsidies, which is not a sustainable business model, nor is it a business model that creates a market that grows on its own.

Improving the investment side will continue to produce better batteries for the applications mentioned in this paper, while decreasing the relative cost. This includes lowering the cost of batteries, and research to increase the density, quality and lifetime. Also, research to develop new types of batteries continues as well. The accelerated introduction of batteries (not only for grid use, but for vehicle use and residential use as well) will lead to higher production rates, which, as the result of economics of scale, tend to push down prices as well.

The biggest problem in the current paradigm is that the structure of the market and regulatory environment tends to place an inadequate value on energy storage. Unless appropriate incentives that reflect a correct economic value of batteries emerge, batteries will have a difficult time penetrating the electric system. However, as is shown below, such market structures are emerging, with rules such as Pay For Performance, and enabling the creation of multiple revenue streams for batteries.

The effect of policy change (The Pay for Performance evaluation system) – The United States

In order to adequately remunerate facilities for their contribution to system stability, the FERC (Federal Energy Regulatory Commission) has published Orders to revise the frequency regulation market of each separately controlled area. One such new system is the Pay for Performance rule in PJM (in the eastern US).

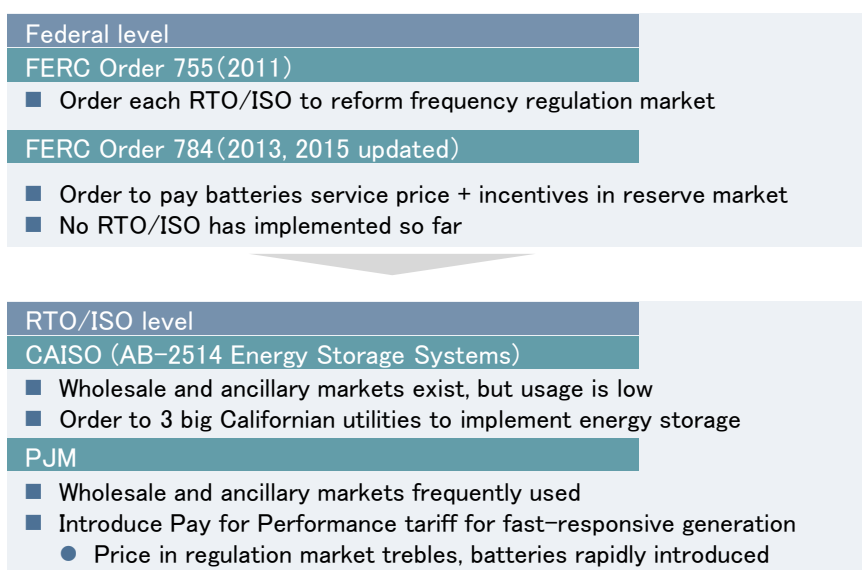

⁸See <http://analysis.energystorageupdate.com/market-outlook/pjm-leads-us-fast-frequency-regulation-market>, last accessed on 2015/10/19.

The implementation of FERC Order 755 has resulted in the PJM Pay for Performance rule, which remunerates for resources providing frequency regulation according to their actual performance. Even though this is a technologically neutral rule, this gives batteries an advantage in the market, since they are more adept at following such signals, compared to, for example, coal power plants. This will lead to an optimization of the system, since fewer coal power plants will engage in inefficient output changes.

Below is an example which shows how a combined cycle unit (left) and a steam unit (right) follows the regulation control signal (green line). In this case, the combined cycle unit would receive a higher fee. Batteries are usually even more accurate than this, which shows how they fit into this market. PJM has also introduced rules for a minimum performance required to bid into the frequency regulation market, thus removing low-performance units from consideration.

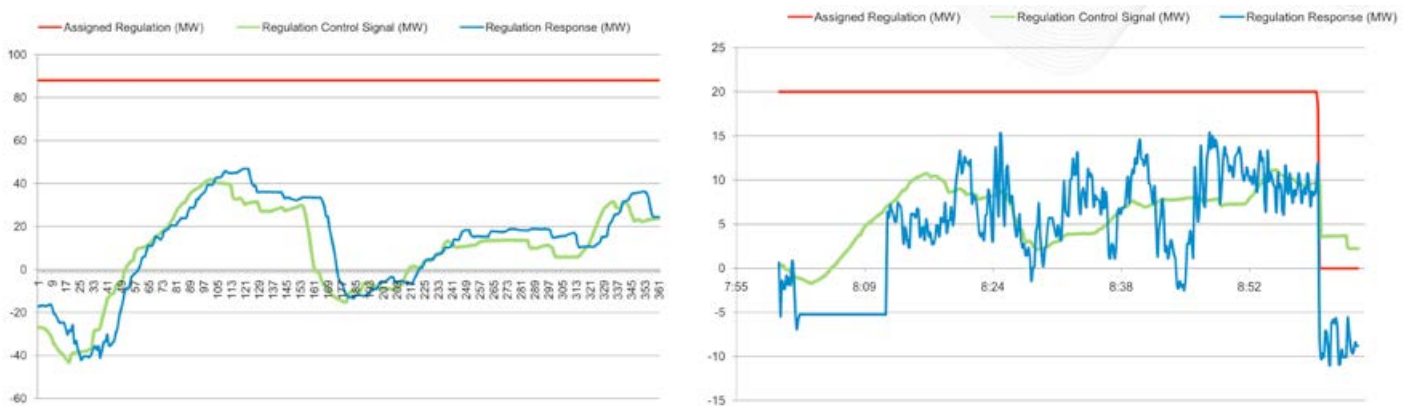

Figure 3-2 Frequency control signal following capability, left: combined cycle, right: steam
Source: "RPSTF Performance Metrics Formulas and Examples", PJM, 2011

Hence, depending on future policy changes, the case for battery grid storage improves greatly. FERC Order 755 has not been implemented in all markets yet, but further implementation will open up new markets. Further, FERC Order 784, issued in July 2013, strengthened the requirements put forth in Order 755, while adding transparency in the ancillary services market by introducing new accounting and reporting rules.

The effect of these kinds of regulation changes is easy to observe. Following the introduction of the Pay for Performance rule in PJM, the average regulation prices in PJM increased, as can be seen in the graph below, whereas the total amount of resources needed to perform frequency regulation dropped from an average of 1,000MW to 700MW. By paying more for the service, but lowering the total amount needed, PJM has managed to make grid operation more efficient. Currently, a total of more than 200MW of batteries have been introduced, and PJM is considering applications for over 500MW of additional power.



Figure 3-3 Monthly average frequency regulation market fees in PJM
Source: NEC presentation material, EUW 2014, modified by author

Other important policy changes in the US

Simultaneously, the NERC (North American Electricity Reliability Corporation) BAL-003 rule proposes to require sufficient frequency response from the balancing authorities (grid operators) by stricter levels than what has historically been the case. NERC BAL-003 requires utilities to maintain a frequency bias setting that allows variations of less than 60 ± 0.036 Hz. This standard attempts to stabilize the grid in an era where generation and demand will become more varied than in times past, and to prevent frequency variations which might cause ripple effects, affecting surrounding grids⁹.

This standard presents a new opportunity to use batteries for frequency regulation, since, as mentioned above, compared to conventional frequency regulation resources they are superior in reacting swiftly.

The change of this kind of regulation is observable from the results in Duke Energy's Notrees (Texas) wind farm battery trial. Experiments were conducted with ERCOT to evaluate how the battery works and the utility of the battery depending on the strictness of the rules for frequency regulation. ERCOT and Duke Energy experimented with the limit setting for when automatic frequency regulation by the battery should start; this resulted in very different scenarios for battery use in the frequency regulation market. In the graph below, it can be seen that stricter rules (60 ± 0.02 Hz, indicated by "59.98" in the graph) will result in an increased activation rate for the battery, generating higher revenue.

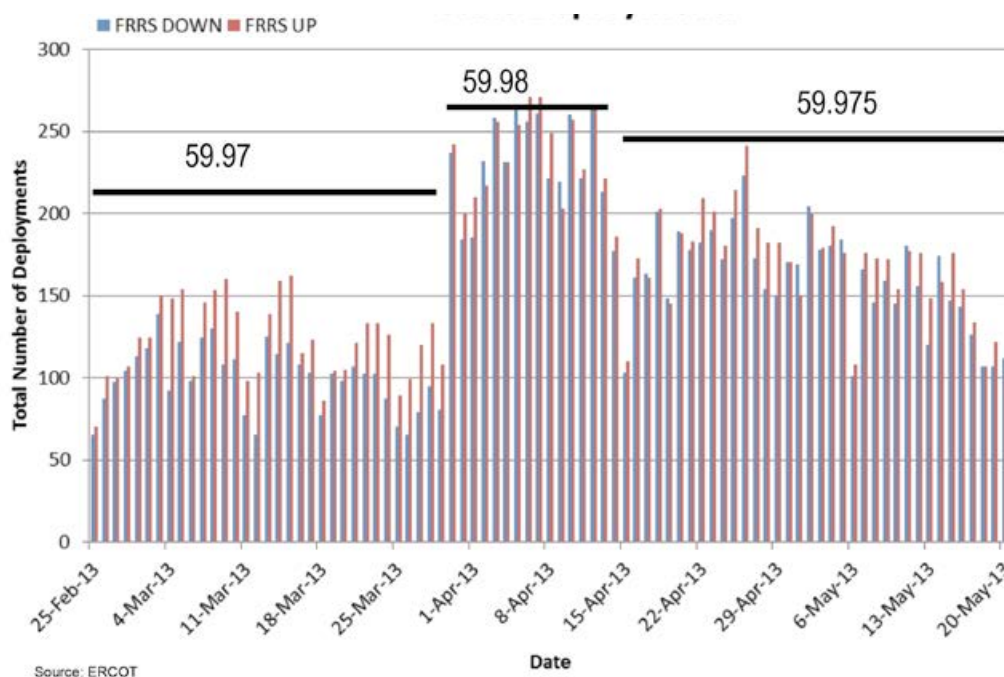

Figure 3-4 Battery activation depending on frequency limit strictness
Source: Duke Energy, EUW 2014 presentation

Policy changes in Europe – Ireland

In Europe, the power industry is evolving in a manner which has the potential to be a game changer for electrical storage. This reflects legislation and policy direction, such as the European Energy Efficiency Directive, but, perhaps most importantly, it also reflects a need to monetarily reward system flexibility. One area that stands out is Ireland and Northern Ireland. Ireland and Northern Ireland form a single synchronous system, interconnected to Great Britain via two 500MW HVDC interconnectors.

In 2011, EirGrid and SONI embarked upon the multi-year DS3 Programme ("Delivering a Secure, Sustainable Electricity System"). The programme was designed to ensure that Ireland and Northern Ireland can securely operate the power system with increasing levels of variable non-synchronous renewable generation (i.e. wind power and HVDC interconnector imports) over the coming years. Together with on-going work on infrastructure development and the addition of renewable generation capacity, the DS3 Programme is critical to meeting the governments' 40% renewable electricity targets by 2020.

⁹For more information, see Interconnection Frequency Response Obligation. < http://www.nerc.com/pa/Stand/Project%20200712%20Frequency%20Response%20DL/Attach_A-Frequency_Response_Standard_Support_Document_Redline.pdf >

A central aspect of the DS3 Programme is the System Services Review. System Services are products, other than energy, that are required for the continuous, secure operation of the power system. Following significant industry consultation, appropriate products and monetary mechanisms were decided.

- An increase in the annual budget cap from €60 million to €235 million
- Doubling the number of System Service products from 7 to 14

In essence, the technical definition of products has evolved and the monetary reward has been significantly increased. An example product is Fast Frequency Response, which is defined as the additional increase in MW output from a generator, or reduction in demand following a frequency event that is available within 2 seconds of the start of the event and is sustained for at least 8 seconds.

These new system services products are technologically neutral, but given the inherent flexibility of batteries, it is believed they are well placed to take advantage of this commercial opportunity.

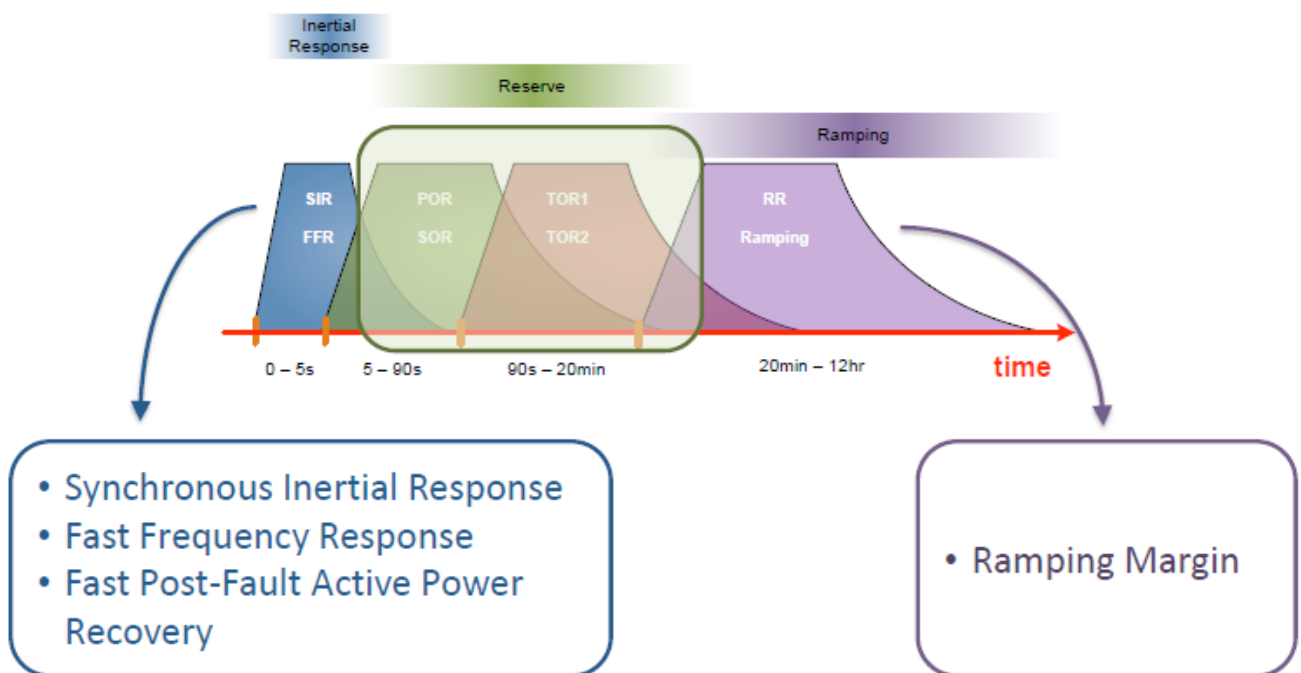
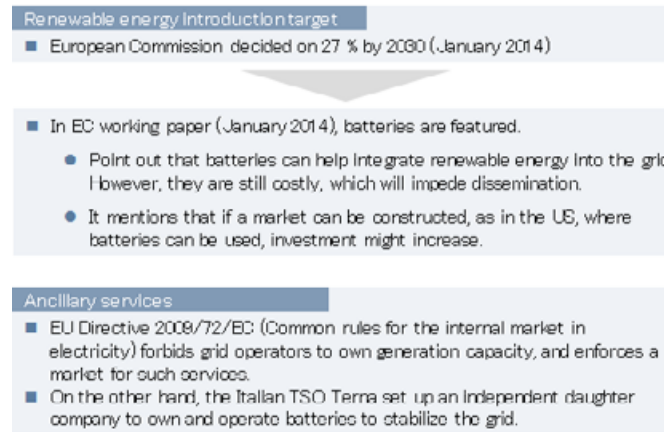

Figure 3-5 Proposed System Services in Ireland
Source: EirGrid

Ownership of batteries by the TSO in Italy

In Italy, large amounts of variable generation, mostly solar PV, have been installed, resulting in grid instabilities. Many of the installations are connected to the distribution grid, and much of it is located in the south, whereas the main demand centers are in the north. Due to this, the largest DSO of Italy, ENEL, has set up an independent daughter company to own and control batteries in the distribution network to absorb the variable generation. European law does not allow for grid operators to directly own and operate assets that participate in the market, since this can disrupt fair competition.



Changing this kind of regulation allows for the front-of-the-meter market to expand.

Other important rule revisions

- State of New York in the US

The State of New York's electricity infrastructure has been aging, and has been hit by several disastrous storms in recent years, demonstrating the vulnerability of the current grid model. Separate from this development, the competitiveness of renewable energy sources has increased. Faced with this, New York has put out a new energy agenda in 2015, "Reforming the Energy Vision (REV)", which will spur clean energy innovation while increasing the resiliency of the grid.

The REV consists of two "tracks": Track one aims to strengthen the distribution utilities position and promote energy efficiency as well and peak shifting at the local level. Track two will examine the current regulation, tariff and market structure. There are expectations that these changes will promote the use of renewable energy, as well as the energy storage installation needed to support the system when variable generation resources increase in capacity.

- State of California in the US – Clarifying the position of batteries in California

The state of California has been the leader in producing rules to encourage the introduction of energy storage. The 1.325GW mandate which was noted earlier in this white paper is one such rule. Another example is SDG&E's "Distribution Resources Plan", in which they issued an RFP for upgrading the distribution infrastructure to prepare it for further distributed generation integration¹⁰.

In addition to the above changes, CAISO (California Independent System Operators) and CEC (California Energy Commission) have been discussing the roles batteries should have in the energy system. In a roadmap published in 2014, three possible scenarios were highlighted.

- Use batteries as part of the transmission network, with the ownership belonging to the grid operator. The revenue would be based on grid tariffs and on participation in the market. However, this model is currently not allowed by the FERC.
- Use batteries to improve the reliability of the distribution network and participate in the wholesale energy market.
- Participate in the wholesale energy market and provide services to lower the load of consumers.

¹⁰The CPUC (California Public Utilities Commission) has, pursuant to California law AV 327, which regulates net metering, issued an "Order Instituting Rulemaking Regarding Policies, Procedures, and Rules for Development of Distribution Resources Plans Pursuant to Public Utilities Code Section 769 (DRP OIR)". SDG&E followed this order by proposing the "Distribution Resources Plan".

CPUC (California Public Utilities Commission), CEC and CAISO began investigating the possibility of changing the FERC rules in the spring of 2015, together with other stakeholders in California.

Other opportunities – multiple revenue streams

Originally, the grid was created for separate parts with separate functions (namely: generation [supply], load [demand], transmission, distribution), and each having separate rules. Energy storage, such as batteries, is capable of occupying many of these positions at once, and providing multiple services at the same time, leading to a degree of institutional confusion.

If, for example, frequency regulation could be combined with other applications, such as voltage control and renewable integration, or used to support the distribution and transmission network while providing frequency regulation, it would increase the economic viability of battery storage in the grid. This is called stacking of revenue streams.

Thus, another possible method to improve the economics of batteries is to increase the number of revenue streams the battery can earn. In many markets today, since batteries are not sufficiently defined in grid codes, the revenue of batteries tends to depend on one function only, when they in fact can produce several services simultaneously.

- Trials in the US

The table below shows the possible combined application uses that the Purdue University State Utility Forecasting Group suggests. The use on the left in bold letters represents the main application, while the ones on the right in parentheses indicate sub applications which will be applied to the extent possible.

Table 3-1 Combining applications of energy storage

(C1)	Frequency Excursion Suppression + (Grid Angular Stability + Grid Voltage Stability + Regulation Control)
(C2)	Short duration Power Quality + (Load Shift 10 hours + Regulation Control + Spinning Reserve)
(C3)	Short duration Power Quality + (Load Shift 3 hours + Regulation Control + Spinning Reserve)
(C4)	Long duration Power Quality + (Load Shift 3 hours + Spinning Reserve + Regulation Control)
(C5)	Load Shift 10 hours + (Spinning Reserve + Regulation Control)
(C6)	Avoid Transmission Curtailment + (Frequency Excursion Suppression + Regulation Control)
(C7)	Renewable Time Shifting + (Frequency Excursion Suppression + Regulation Control)
(C8)	Forecast Hedging + (Frequency Excursion Suppression + Regulation Control)
(C9)	Fluctuation Suppression + (Frequency Excursion Suppression + Renewable Time Shifting)

Source: "Utility Scale Energy Storage Systems" State Utility Forecasting Group, June 2013, p.17

The report above by the State Utility Forecasting Group is a theoretical approach. However, there are field trials as well. Mentioned earlier in this paper, Duke Energy's Notrees project is an example where multiple revenue streams are being projected, namely frequency regulation and wholesale energy market participation.

Table 3-2 Notrees Project overview

Developer	Duke Energy and Xtreme Power (XP)
Battery	Advanced lead-acid battery technology (36MW/24MWh output) 24 Dynamic Power Modules with 1.5MW/1MWh
Schedule	Construction began Oct 2011, operational Dec. 2012 Two-year system performance testing: 2013-14 ERCOT FRRS Program: Feb. 2013 – March 2014
Markets	Primary Commercial Market – ERCOT (ERCOT Frequency Regulation, FRRS Pilot) Potential future markets: Energy arbitrage, voltage support, wind firming, curtailment mitigation
Project Location	

Source: Duke Energy presentation material (European Utility Week 2014)

Duke Energy is looking to combine 1) energy arbitrage (wholesale selling and buying of electricity) with 2) participation in ancillary services market (frequency regulation) and 3) non-market services (black start). The economic benefits of this can be seen by studying the graphs Duke Energy has produced from their trials at Notrees. Below is the state of charge of the trial battery, depending on whether the battery was used for only the wholesale energy market, or for both the energy market and frequency regulation. The battery is clearly used more often in the latter case, thus creating more value.

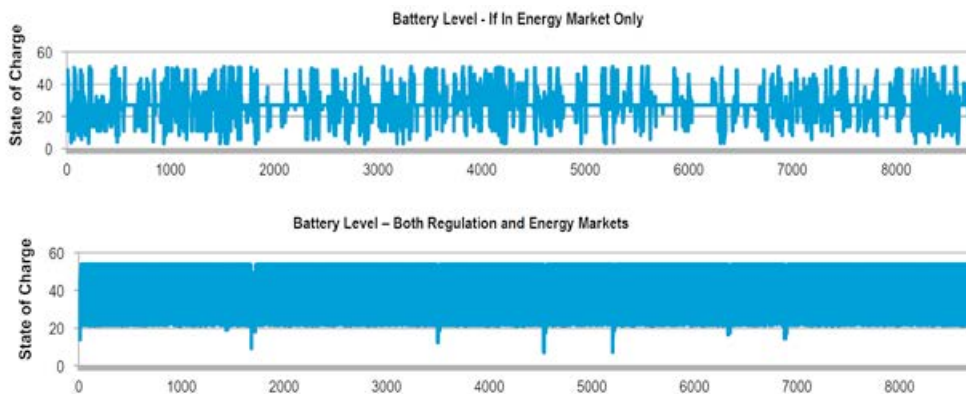

Figure 3-6 Comparison of singular use versus multiple use of batteries

One issue that remains, though, is how to classify batteries. In current Texan legislation (SB 943), batteries operating in the wholesale market are classified as generation assets; however, there are many discrepancies between generation and energy storage, which makes the registration process troublesome, and limits the ways the battery can produce revenue. There have been discussions about creating a separate category for energy storage, but for the time being, this has not been realized (see the appendix for other examples of attempts at creating multiple revenue streams models). From this, it can be said that changing market regulations regarding multiple market participation would increase the economic viability of batteries.

Evolution of the market

As seen above, there are several market opportunities for using batteries in the power grid; some have already arrived, whereas others are beginning to open up. Based on discussions with the work group members, the following vision for an evolution of the market was conceived. The figure below is a generalized vision on how the market will evolve, and there are apparently exceptions to this, due to specific conditions in each country.

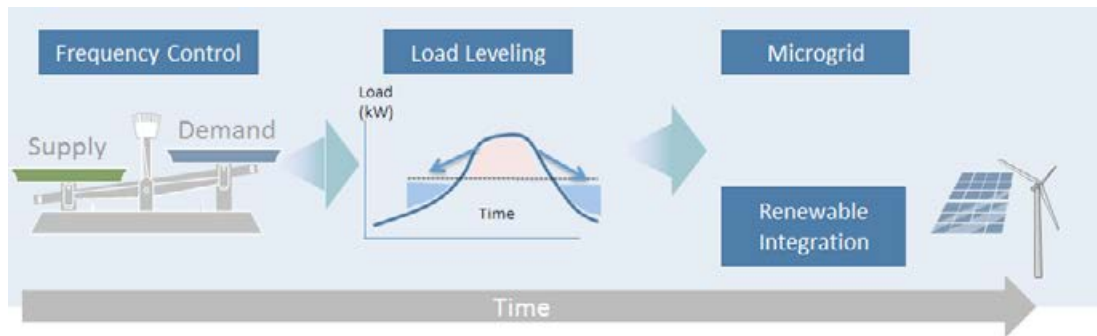

Figure 3-7 Evolution of the market for power grid battery use

It was agreed upon by the WG that using batteries for frequency control to stabilize the grid is the application that is most economical at present, and there are many market opportunities opening up. However, the size of the regulation market as such is not large, and even though it might grow larger due to the introduction of more renewable energy, it will be saturated relatively quickly.

Next, the use of batteries will expand to grid upgrade deferral, shifting local peaks. As with frequency control, there are already areas where this use of batteries is economically viable, as in Queensland, Australia.

Finally, the market will open up to microgrids and renewable integration. All stakeholders agreed that renewable integration is the potentially largest market for energy storage, since storage can be supplied at each generation point, and will probably have to be supplied once renewable energy penetration rates go up.

Voltage control was not perceived as a market that will open up on its own; it is rather thought of as an auxiliary service.

4 CONCLUSION

The introduction and integration of variable renewable generation and distributed generation into the power grid has occurred rapidly over the last decade, and the pace is likely to accelerate into the future. This will require a higher ability to keep the balance of generation and demand in the grid, even if dispatchable resources are diminishing.

One asset that can greatly increase the reliability of the grid is battery energy storage. Whereas batteries are often seen as too expensive to make economic sense in comparison with existing solutions, it is shown in this paper that there are already market conditions where batteries can thrive as a solution for grid issues. On the other hand, further development is necessary to improve integration of distributed multiple batteries into the system control.

The largest obstacle facing the industry today is bridging the gap between using batteries for demonstration projects, and being a viable economic solution. The key here is to create a regulatory environment that can adequately value battery energy storage economically. This will in turn increase production, lowering prices for batteries so they become economical for important applications, such as renewable energy integration, even without subsidies.

As a general rule frequency regulation will be the first market to appear and after that, load leveling/peak shifting will evolve into a feasible market. However, these two markets are limited in size. Finally, the market will progress such that renewable integration becomes economically viable. This represents the largest market for battery energy storage. This is but a general trend from which there can be many exceptions depending on country, especially in very small grids, where microgrid use will be an important market.

In order to realize these markets, the creation of a regulatory framework that on a technologically neutral basis can adequately value the functions of batteries, such as the system services that are being created in Ireland, is needed. This will in turn help the power grid become more efficient, increasing the possible amount of renewable generation which can be integrated.

APPENDICES



Table A-1 Working group board member list

Affiliation	Name	Status
JSCA/NEDO	Hiroshi Kuniyoshi	Leader of the working group
Australia	Bob Darwin, Ke Meng, Andy Zhao	Member
Denmark	Helle Juhler-Verdoner	Member
Flanders	Sven van den Bosch	Member
France	Davy Theophile	Member
Netherlands	Hans van der Spek	Member
Ireland	Robbie Aherne	Member
Japan	Mitsue Takagi Yuichiro Shimura, David Helsing	Member
South Korea	Sang-ho Ahn	Member
Norway	Kjell Sand	Member
United States	Steve Hauser	Member

Proposed Scope of the Work Group

GSGF Power Grid Electrical Energy Storage Work Group Charter (Draft)

October 27, 2014

1. Background of this Work Group

Use of renewable energy for realizing a lower carbon future has been a growing international trend. However, electricity generated by solar and wind power fluctuates sharply, causing such problems as grid voltage and frequency instability. Therefore, expectations regarding electrical energy storage technology have been increasing as it may be an effective means of mitigating the impact of inherently variable power sources on grid systems.

In the United States, for example, the state government of California recently mandated that electric utilities procure 1.3GW of electrical energy storage by 2020 in order for them to generate one-third of their power from renewable energy.

The WG will therefore identify possible grid-related issues expected to emerge due to external environmental change, including the spread of renewable energy and others. It will also organize case studies on the use of battery systems as electric energy storage toward a resolution of identified issues, determine the status of functions necessary for battery systems to address such issues, and evaluate the feasibility of such functions from the perspective of technical, economical and regulatory aspect. Based on the outcome, the WG will clarify the effect of battery system as electrical energy storage and submit recommendations for further dissemination of battery systems to policymakers and potential battery systems users (customers, utilities, grid operators, etc.).

Accordingly, the WG plans to conduct a study on the following:

1. Organization of possible grid-related issues associated with external environmental change (the need for a solution using diffusion of renewable energy, etc.)
2. Collection and analysis of cases using battery systems as energy storage to address issues (case studies)
3. Recommendation on the role of battery systems toward resolution of grid-related issues

2. Statement of Work (SOW)

1. Organization of possible grid-related issues associated with external environmental change (organizing issues caused by the prevalence of renewable energy)
 - Issues caused by the dissemination of renewable energy
 - Other issues such as to keep voltage quality.

2. Collection and analysis of cases using battery systems to address issues (case studies)
 - Collection of case studies
 - Collect information on type of energy storage system used, the reason(s) it is being used, and what is the plan for use (Information will be collected by members).
 - Analysis of case studies
 - Analyze cases to identify the type of functions that can be realized for battery systems as electrical energy storage. Organize functions that can be realized for battery systems instead of preparing individual use cases. (Frequency regulation, rapid run-up (load following), etc.)
 - Analyze Impacts of high share of renewables into electricity wholesale markets and benefits of electrical energy storage in stabilizing electricity wholesale prices, and ultimately supporting renewables market integration.

3. Recommendation on the role of battery systems toward resolution of grid-related issues
 - Extraction of issues to be solved (the issues organized in 1) above
Examples of issues:
 - Peak shaving/load management/demand response
 - Load following/balancing
 - Renewable generation smoothing/dispatch
 - Islanding
 - Frequency regulation/grid stabilization
 - Voltage/power factor regulation
 - Organizing functions to be provided by battery systems (based on the outcome of 2) above
 - What functions are feasible in terms of economic efficiency and other considerations
 - Recommendation on the roles of battery systems as electric energy storage from the perspective of technical, economical and regulatory aspect.
(Tentative)
 - Some energy storage system applications using batteries are already economically feasible.
 - Further utilization of energy storage system applications using batteries can be expected.
 - Demonstrations and other efforts to procure an optimal capacity of energy storage for suitable applications are necessary.(In accordance with 1) and 2) above, recommendations on the role expected of energy storage system applications using batteries and future action will be submitted.)

* If the battery system proves to be not economically efficient, an estimation of the expected year (in the future) when the case will be break-even due to declining prices and rise in expected issues should be provided.

3. Schedule

Send charter to members of Electrical Energy Storage Working Group and request feedback (any proposals for amendment)	End of September to mid-October
Amend and finalize charter	End of October
Send first draft of white paper to members	March to April 2015
Complete white paper	June to July 2015

Note: Ad-hoc teleconferences will be conducted on an as-needed basis.

(END)

Table C-1 Schedule of the activities of the working group

Date	Activities
November 2014	GSGF board of directors approved of setting up the work group.
December 2014	Stated the work group activities. Sent first questionnaire to the members.
January 2015 to February 2015	Communicated among members by e-mail.
March 2015	First teleconference
July 2015	Second teleconference Second questionnaire sent to members
September 2015	Preliminary draft white paper Face-to-face discussions with some members
October 2015	Second draft of white paper
November 2015	Member feedback (Scheduled)
December 2015	Finalizing and publishing of white paper (Scheduled)

APPENDIX D RESULTS OF THE QUESTIONNAIRES

Two questionnaires aimed at the experts of the working group were undertaken to grasp the current situation of battery storage in the power grid, and to gather opinions on what measures might be effective in promoting the introduction of batteries.

Overview of the first questionnaire

During the preparation of the white paper, many relevant reports and papers were reviewed. However, instead of a review of already existing studies, the team decided to base the research for this white paper on the discussions between experts from several countries.

10 completed questionnaires were collected. 7 of the respondents believe that new needs for energy storage are emerging. All 7 respondents believe that batteries can be used, if certain conditions are met.

The expectations for using batteries for frequency regulation, further introduction of renewable energy, load leveling/peak shifting are significant. On the other hand, opinions on the use for spinning reserves and voltage control are split.

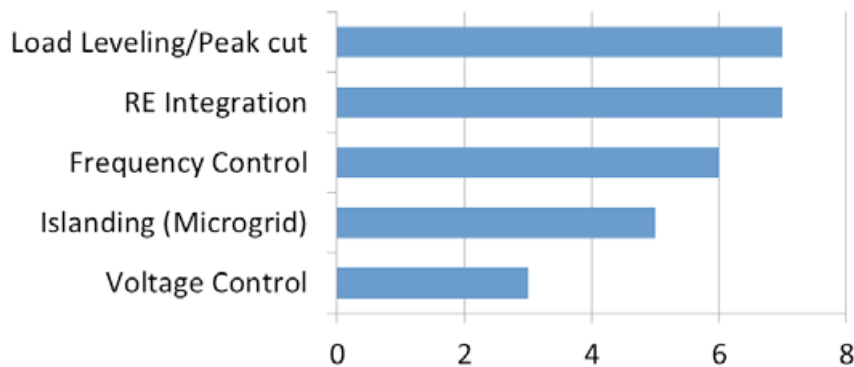

Figure D-1 Expected applications for battery energy storage

Many possible policies to help introducing batteries were given. For example, some prominent opinions were as follows:

- Battery storage should be defined as a function in the transmission and distribution network (and not be viewed as load or generator)
- The DSO should be allowed to independently introduce measures to increase the flexibility of the network.
- There should be discussions on who should be able to own and operate batteries (TSO, DSO, others).
- In the short term, batteries should be handled technologically neutrally, but in the medium to long term the European Energy Efficiency Directive might drive the introduction of batteries for grid storage.
- Further introduction of RE, and the institutionalization of BCPs (Business Continuity Plans) would help.
- Financial incentives such as FIT might boost demand for batteries.

Overview of the second questionnaire

A second questionnaire was conducted to clarify some of the answers from the first questionnaire, and to get additional feedback. The second questionnaire mainly consists of text-based answers, and therefore simple aggregation was difficult. A total of 8 questionnaires were collected.

Below are the conclusions that were drawn from the individual answers on possible applications for batteries.

Table D-1 Opportunities and threats for battery storage in different applications

Application	Summary of opportunities	Summary of threats
Frequency regulation	Frequency regulation market for wide-area grids is universally seen as a strong point. In Asia, keeping frequency within stable boundaries in small grids is gathering attention.	For frequency control, there are many threats, in addition to other storage devices and system wide services (synthetic inertia, interconnectors) being the biggest ones.
Renewable integration	Smoothing the output of renewable generation and increasing flexibility of distributed generation, together with minimizing curtailment are important possible uses.	Other forms of energy storage are potential threats to batteries.
Load leveling	Prevention of distribution line congestion and shaving the peak at substation level are important.	In load leveling, DR is seen as a complimenting technology/threat to batteries.
Microgrid	Batteries are seen as a possible tool to increase the reliability of microgrids, as well as supporting intentional islanding. Increasing self-consumption is also important.	Non-electrical storage, such as heat storage, and other small generators are seen as competitive technologies in the microgrid.
Voltage control	Smooth integration of renewables in local areas is seen as the most important role for batteries and voltage control.	Various network control devices are seen as a threat, as they can also handle voltage.

Regarding the disadvantages of batteries, 5 out of 8 respondents felt that the economics are the main barrier. On the other hand, the durability and safety of batteries are not questioned much anymore.

The respondents also voiced opinions on appropriate measures to move forward with implementing batteries for grid support: it is important to create a regulatory environment which allows for the use of battery storage without hindrance, and to provide economic support in the early stages.

Mobile battery energy storage solution

Hitachi has created a mobile battery energy storage solution called “CrystEna”, consisting of lithium-ion batteries, PCS, and a control device all fitted into one container. Since the solution is provided as a package, it can be installed very quickly at the site where storage is needed. Below are the details of the system.

Table E-1 System specifications for “CrystEna”

Item	Specifications
System output	±1 MW
PCS	500 kW × 2 units
Battery	450-kWh lithium ion battery
Standard	PCS UL 1741
Expected life	System: 15 years or longer Battery: 10 years or longer
Cooling system	Air cooling
Size	40 ft-class container

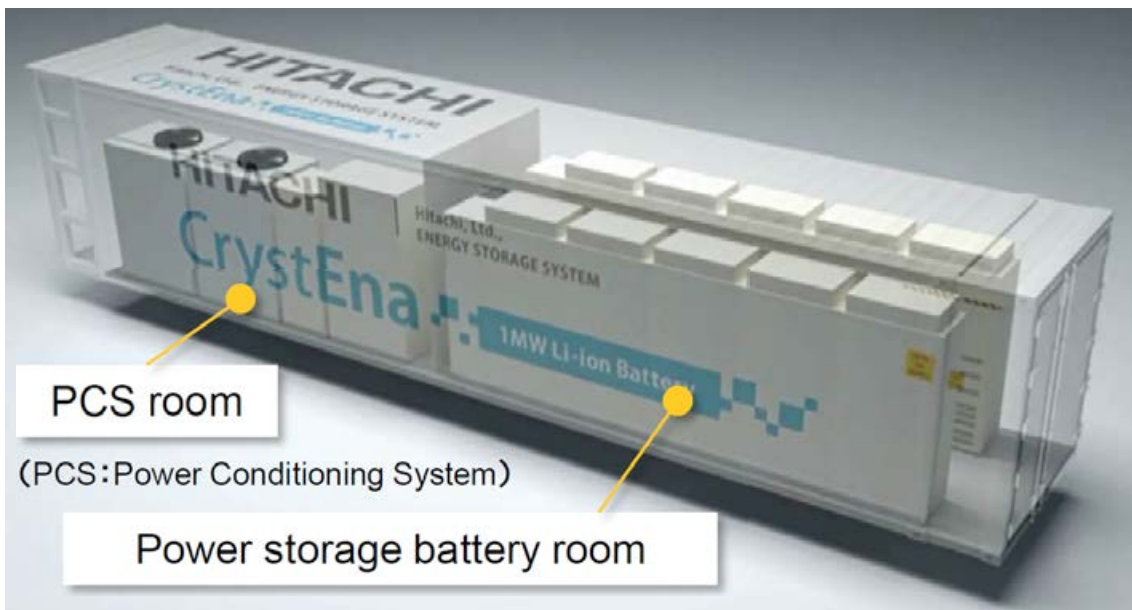

Figure E-1 “CrystEna” product image

Multiple revenue stream model product in Japan

Mitsubishi Electric has developed an ad-hoc solution called “BLENder®-RE” to manage and control generation resources. The generation resource can be renewable energy and batteries, or a combination of these with conventional generation resources.

The typical system is a 1MW/0.5MWh battery system connected to a smaller grid, and it can be used to balance supply-demand through frequency regulation while shifting the peak slightly, as well as managing local voltage control.

Below is an image of the system, with an example of the multi-objective mode that can be applied.

- Central control for load following
 - Central control for VAR compensation
 - Local feed-back control for frequency regulation
 - Local feed-back control for voltage stability
- } Fast and accurate control without communication network

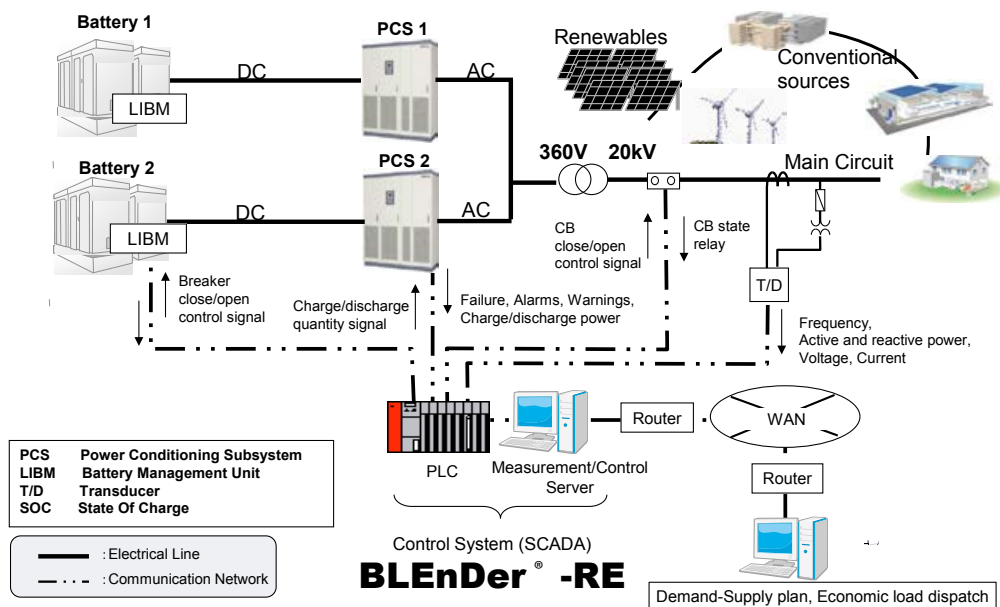

Figure E-2 BLENder®-RE concept image

Source: Mitsubishi Electric presentation material (Smart Community Summit 2015/6/18)

